

REV.	ECO #	DESCRIPTION	DATE	NAME
A	---	N/A	7/6/17	MJR

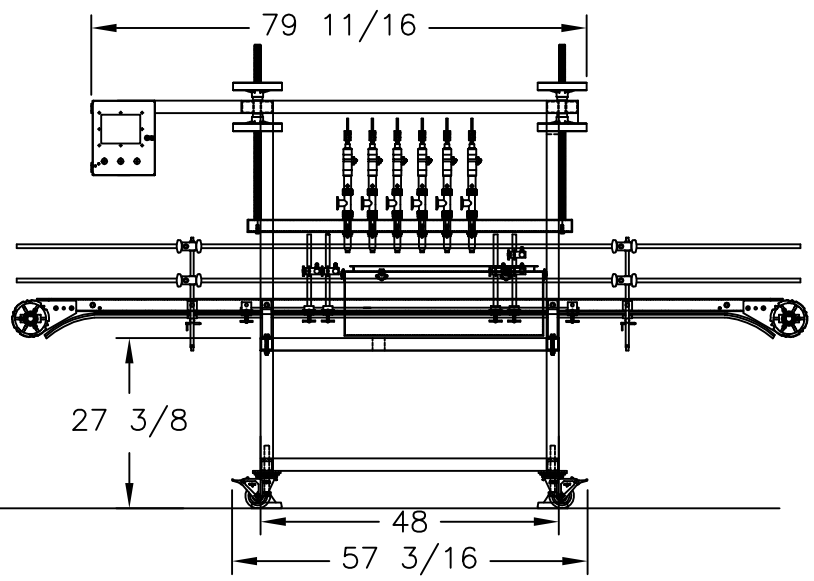

→
CONVEYOR
DIRECTION

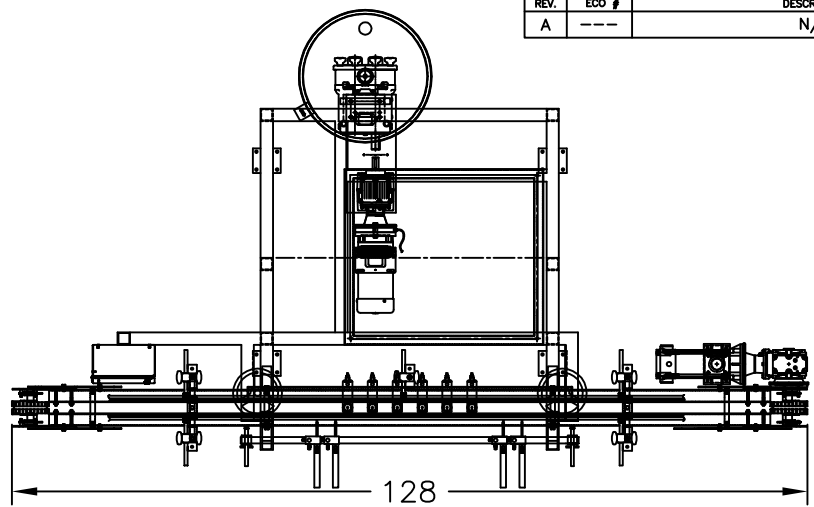
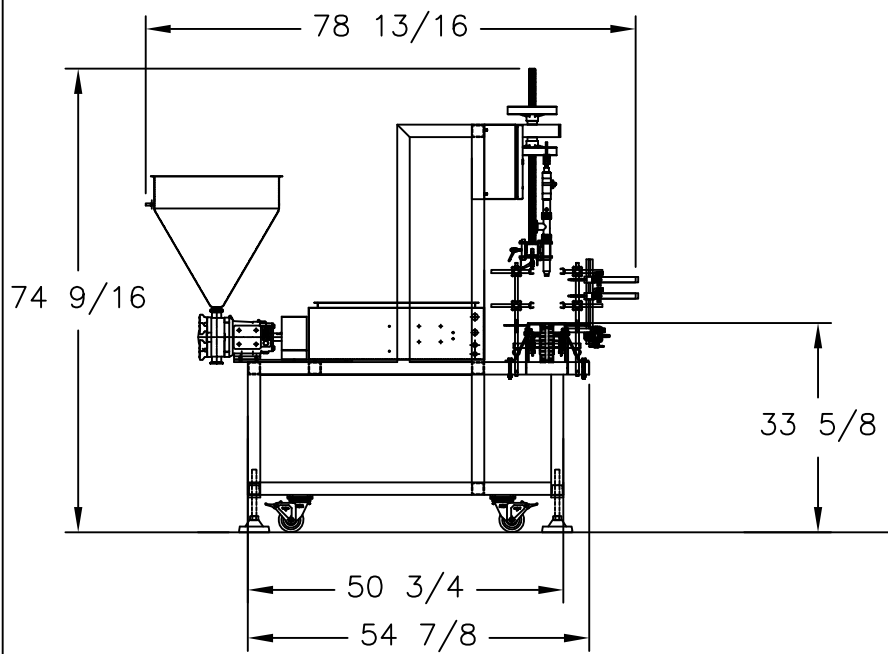

-NOTE-
 1) ALL WELDS SHOULD BE GROUND AND POLISHED SMOOTH TO A #3 (150 GRIT) FINISH.
 2) ALL ROUGH EDGES SHOULD BE CLEANED OF ANY BURR'S.
 3) ALL ANGLES ARE AT 90° UNLESS OTHERWISE NOTED.
 4) ALL RADIUS AND CORNERS ARE TO BE A 1/32 UNLESS OTHERWISE NOTED.

DIMENSIONS ARE IN INCHES UNLESS OTHERWISE NOTED
 REMOVE BURRS AND SHARP EDGES
 TOLERANCES UNLESS OTHERWISE NOTED:
 ANGLES ±0°-30'
 FRACTIONS ±1/32
 DECIMALS:
 .X ±.030
 .XX ±.010
 .XXX ±.005

PROJECT NO.	
PROJECT NAME	
PART NAME	
LAYOUT, GEN 6 PROMATIC W/ ODEN CONVEYOR	
FINISH	QTY
#3	ONE (1)
MATERIAL	304 S.S.

ODEN MACHINERY, INC.
 199 FIRE TOWER DRIVE
 TONAWANDA, NEW YORK USA 14150
 PHONE (716)-874-3822
 TOLL FREE (800)-455-3822
 FAX (716)-874-3000

THIS MATERIAL IS THE EXCLUSIVE PROPERTY OF ODEN MACHINERY, INC. ANY DUPLICATION, RETENTION OR TRANSMITTAL TO OTHERS IS PROHIBITED WITHOUT PRIOR CONSENT.

SCALE	DRAFT	DATE	ENGR	SHEET	DRAWING NO.
20X		4/13/20	DCM	1 OF 1	OM1034-389