

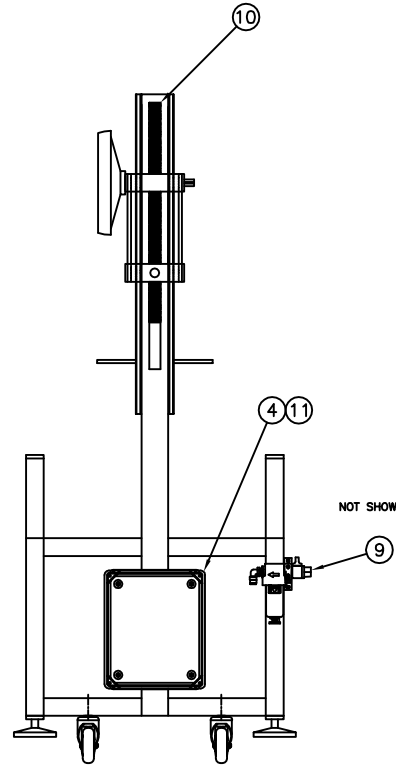

REV.	ECO #	DESCRIPTION	DATE	NAME
B	---	UPDATED DRAWING	6/29/18	DCM

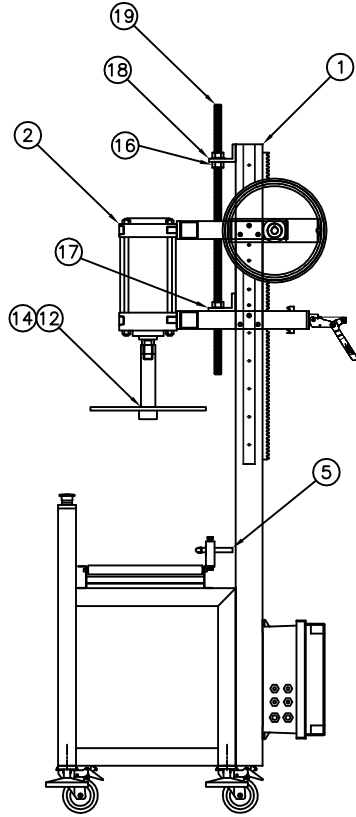
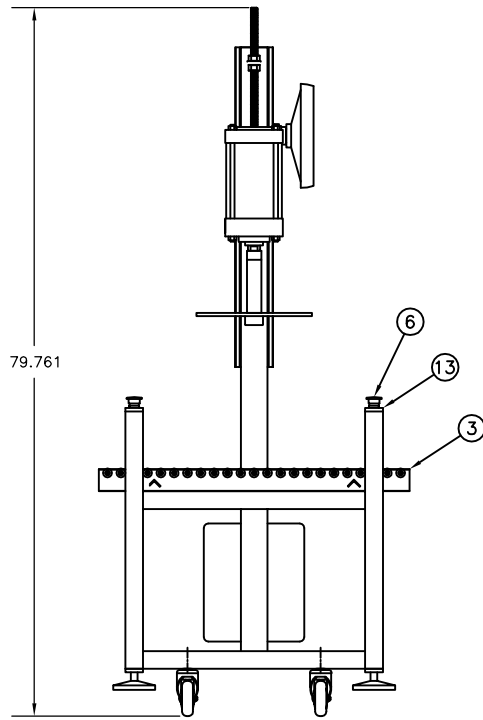
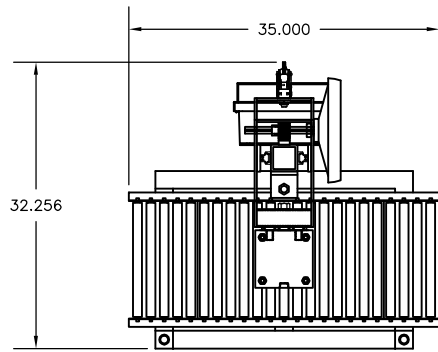

REF	QTY	DESCRIPTION	PART NO.
19	1	ROD, THREADED 3/4-10 UNC 30" LG.	OM1010-045
18	1	BRACKET, UPPER ANGLE MOUNT S.S.	OM1000-078
17	1	BRACKET, ANGLE MOUNT S.S.	OM1000-079
16	4	NUT, 3/4-10UNC BRASS	OM1003-011
15	2	GROMMET,PUSH-IN 5/16"D x 3/4"OD FOR 1/2" DIA. HOLE	OM1133-002
14	1	SCREW, FSHCS, 5/16-18 X 1 1/4" LG.	OM1122-135
13	2	2" PLASTIC CAP	OM1075-007
12	1	CLOSER PLATE 13"Ø 1-8 THREAD ASSEMBLY	OM5047-142
11	1	HOFFMAN ENCLOSURE SUBPLATE ASSEMBLY	OM5500-075
10	1	30" RACK SECTION	OM1103-012
9	1	AIR-IN ASSEMBLY FOR CI MACHINES	OM5500-001
6	2	MUSHROOM HEAD PUSH BUTTONS, CAMOZZI	OM1081-023
5	1	ADJUSTABLE PAIL CENTERING RAIL ASSEMBLY	OM1009-019
4	1	HOFFMAN ENCLOSURE ASSEMBLY	OM5500-076
3	1	CONVEYOR (ROLL-A-WAY) 15" WIDE 35" LONG	OM1608-015
2	1	RACK AND PINION SLEEVE SLIDE EXPLODED ASSEMBLY	OM1080-013
1	1	CLS-25 PAIL CLOSER FRAME ASSEMBLY	OM5500-215

-NOTE-  
 1) ALL WELDS SHOULD BE GROUND AND POLISHED SMOOTH TO A #3 (150 GRIT) FINISH.  
 2) ALL ROUGH EDGES SHOULD BE CLEANED OF ANY BURR'S.  
 3) ALL ANGLES ARE AT 90° UNLESS OTHERWISE NOTED.  
 4) ALL RADIUS AND CORNERS ARE TO BE A 1/32 UNLESS OTHERWISE NOTED.

DIMENSIONS ARE IN INCHES UNLESS OTHERWISE NOTED		PROJECT NO.		 <b>ODEN MACHINERY, INC.</b> 199 FIRE TOWER DRIVE TONAWANDA, NEW YORK USA 14150 PHONE (716)-874-3822 TOLL FREE (800)-459-3822 FAX (716)-874-3000						
REMOVE BURRS AND SHARP EDGES		PROJECT NAME								
TOLERANCES UNLESS OTHERWISE NOTED:		CI CLOSER (STAINLESS RACK)								
ANGLES ±0°-30° FRACTIONS ±1/32		PART NAME		THIS MATERIAL IS THE EXCLUSIVE PROPERTY OF ODEN MACHINERY, INC. ANY DUPLICATION, RETENTION OR TRANSMITTAL TO OTHERS IS PROHIBITED WITHOUT PRIOR CONSENT.						
DECIMALS:		ASSEMBLY, CLS 25 PAIL CLOSER FRAME WELDMENT								
.X ±.030		FINISH		QTY	SCALE	DRFT	DATE	ENGR	SHEET	DRAWING NO.
.XX ±.010		-		ONE (1)	1"=14"	MJR	12/4/15	MJR	1 OF 1	OM5500-213
.XXX ±.005		MATERIAL		316 S.S.						