

REV.	ECO #	DESCRIPTION	DATE	NAME
A		-	4/30/20	DCM

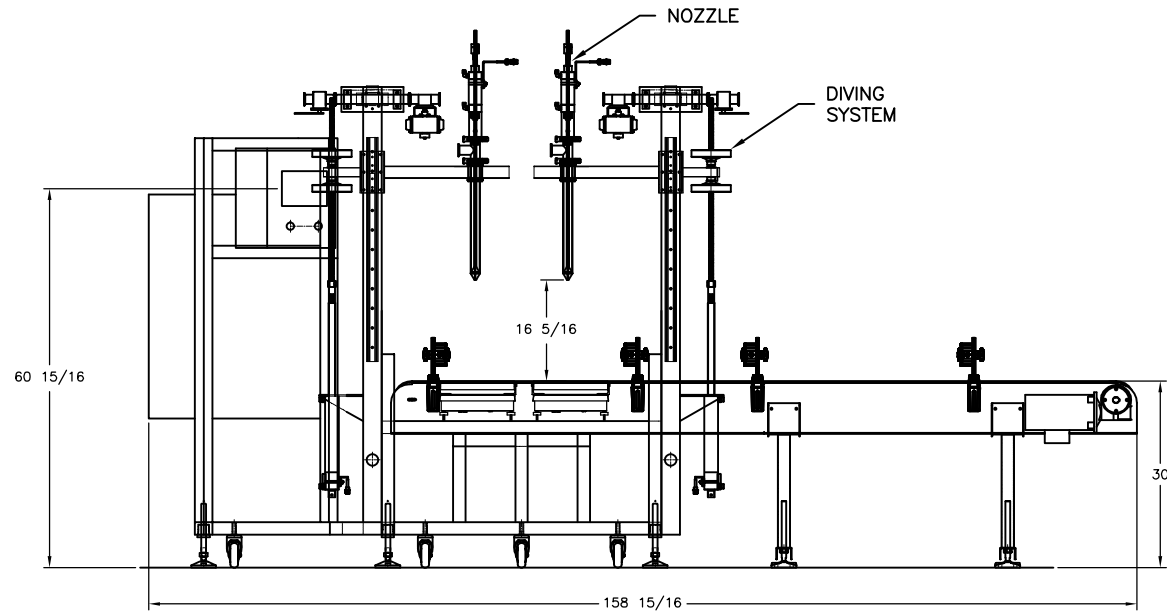

- NOTE-
- 1) ALL WELDS SHOULD BE GROUND AND POLISHED SMOOTH TO A #3 (150 GRIT) FINISH.
  - 2) ALL ROUGH EDGES SHOULD BE CLEANED OF ANY BURR'S.
  - 3) ALL ANGLES ARE AT 90° UNLESS OTHERWISE NOTED.
  - 4) ALL RADIUS AND CORNERS ARE TO BE A 1/32 UNLESS OTHERWISE NOTED.

DIMENSIONS ARE IN INCHES UNLESS OTHERWISE NOTED REMOVE BURRS AND SHARP EDGES TOLERANCES UNLESS OTHERWISE NOTED: ANGLES ±0°-30' FRACTIONS ±1/32 DECIMALS: .X ±.030 .XX ±.010 .XXX ±.005	PROJECT NO.		PROJECT NAME		PART NAME	
	LAYOUT, 2 HD CI		PAIL FILLER (SEMI- AUTO)		QTY	1
	FINISH	-	MATERIAL	304 S.S.		

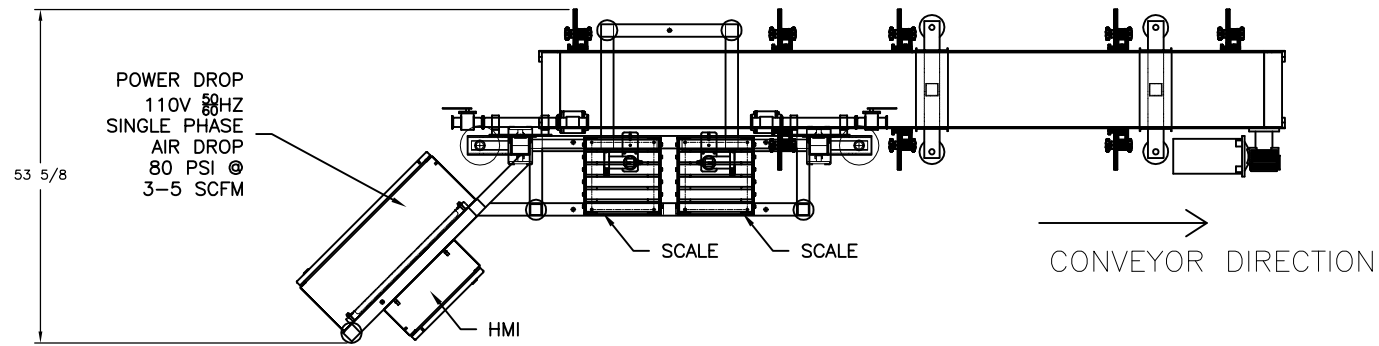

**ODEN MACHINERY, INC.**  
 199 FIRE TOWER DRIVE  
 TONAWANDA, NEW YORK USA 14150  
 PHONE (716)-874-3822  
 TOLL FREE (800)-459-3822  
 FAX (716)-874-3000

THIS MATERIAL IS THE EXCLUSIVE PROPERTY OF ODEN MACHINERY, INC. ANY DUPLICATION, RETENTION OR TRANSMITTAL TO OTHERS IS PROHIBITED WITHOUT PRIOR CONSENT.

SCALE	DRFT	DATE	ENGR	SHEET	DRAWING NO.
1"=20"	DCM	4/30/20	DCM	1 OF 1	OM1034-392